

Agilent 16065A EXT Voltage Bias Fixture

Operation and Service Manual

Second Edition



Agilent Technologies

Agilent Part No. 16065-90010

January 2000

Printed in Japan

Notices

The information contained in this document is subject to change without notice.

This document contains proprietary information that is protected by copyright. All rights are reserved. No part of this document may be photocopied, reproduced, or translated to another language without the prior written consent of the Agilent Technologies.

Agilent Technologies Japan, Ltd.

Component Test PGU-Kobe

1-3-2, Murotani, Nishi-Ku, Kobe-shi, Hyogo, 651-2241 Japan

© Copyright Agilent Technologies Japan, Ltd. 1990, 2000

Manual Printing History

The manual's printing date and part number indicate its current edition. The printing date changes when a new edition is printed. (Minor corrections and updates that are incorporated at reprint do not cause the date to change.) The manual part number changes when extensive technical changes are incorporated.

1990	First Edition
January 2000	Second Edition

Safety Summary

The following general safety precautions must be observed during all phases of operation, service, and repair of this instrument. Failure to comply with these precautions or with specific WARNINGS elsewhere in this manual may impair the protection provided by the equipment. In addition it violates safety standards of design, manufacture, and intended use of the instrument.

The Agilent Technologies assumes no liability for the customer's failure to comply with these requirements.

NOTE	16065A comply with INSTALLATION CATEGORY II and POLLUTION DEGREE 2 in IEC61010-1. 16065A are INDOOR USE product.
-------------	--

NOTE	LEDs in 16065A are Class 1 in accordance with IEC60825-1. CLASS 1 LED PRODUCT
-------------	--

- Ground The Instrument
To avoid electric shock hazard, the instrument chassis and cabinet must be connected

to a safety earth ground by the supplied power cable with earth blade.

- **DO NOT Operate In An Explosive Atmosphere**

Do not operate the instrument in the presence of flammable gasses or fumes. Operation of any electrical instrument in such an environment constitutes a definite safety hazard.

- **Keep Away From Live Circuits**

Operating personnel must not remove instrument covers. Component replacement and internal adjustments must be made by qualified maintenance personnel. Do not replace components with the power cable connected. Under certain conditions, dangerous voltages may exist even with the power cable removed. To avoid injuries, always disconnect power and discharge circuits before touching them.

- **DO NOT Service Or Adjust Alone**

Do not attempt internal service or adjustment unless another person, capable of rendering first aid and resuscitation, is present.

- **DO NOT Substitute Parts Or Modify Instrument**

Because of the danger of introducing additional hazards, do not install substitute parts or perform unauthorized modifications to the instrument. Return the instrument to a Agilent Technologies Sales and Service Office for service and repair to ensure that safety features are maintained.

- **Dangerous Procedure Warnings**

Warnings, such as the example below, precede potentially dangerous procedures throughout this manual. Instructions contained in the warnings must be followed.

WARNING

Dangerous voltages, capable of causing death, are presenting this instrument. Use extreme caution when handling, testing, and adjusting this instrument.

Safety Symbol

General definitions of safety symbols used on the instrument or in manuals are listed below.



Instruction Manual symbol: the product is marked with this symbol when it is necessary for the user to refer to the instrument manual.



Alternating current.



Direct current.



On (Supply).



Off (Supply).



In position of push-button switch.



Out position of push-button switch.



Frame (or chassis) terminal. A connection to the frame (chassis) of the equipment which normally include all exposed metal structure.

WARNING This warning sign denotes a hazard. It calls attention to a procedure, practice, condition or the like, which, if not correctly performed or adhered to, could result in injury or death to personnel.

CAUTION This Caution sign denotes a hazard. It calls attention to a procedure, practice, condition or the like, which, if not correctly performed or adhered to, could result in damage to or destruction of part or all of the product.

NOTE Note denotes important information. It calls attention to a procedure, practice, condition or the like, which is essential to highlight.

Certification

Agilent Technologies certifies that this product met its published specifications at the time of shipment from the factory. Agilent Technologies further certifies that its calibration measurements are traceable to the United States National Institute of Standards and Technology, to the extent allowed by the Institution's calibration facility, or to the calibration facilities of other International Standards Organization members.

Warranty

This Agilent Technologies instrument product is warranted against defects in material and workmanship for a period corresponding to the individual warranty periods of its component products. Instruments are warranted for a period of one year. Fixtures and adapters are warranted for a period of 90 days. During the warranty period, Agilent Technologies will, at its option, either repair or replace products that prove to be defective.

For warranty service or repair, this product must be returned to a service facility designated by Agilent Technologies. Buyer shall prepay shipping charges to Agilent Technologies and Agilent Technologies shall pay shipping charges to return the product to Buyer. However, Buyer shall pay all shipping charges, duties, and taxes for products returned to Agilent Technologies from another country.

Agilent Technologies warrants that its software and firmware designated by Agilent Technologies for use with an instrument will execute its programming instruction when property installed on that instrument. Agilent Technologies does not warrant that the operation of the instrument, or software, or firmware will be uninterrupted or error free.

Limitation of Warranty

The foregoing warranty shall not apply to defects resulting from improper or inadequate maintenance by Buyer, Buyer-supplied software or interfacing, unauthorized modification or misuse, operation outside the environmental specifications for the product, or improper site preparation or maintenance.

IMPORTANT

No other warranty is expressed or implied. Agilent Technologies specifically disclaims the implied warranties of merchantability and fitness for a particular purpose.

Exclusive Remedies

The remedies provided herein are buyer's sole and exclusive remedies. Agilent Technologies shall not be liable for any direct, indirect, special, incidental, or consequential damages, whether based on contract, tort, or any other legal theory.

Assistance

Product maintenance agreements and other customer assistance agreements are available for Agilent Technologies products.

For any assistance, contact your nearest Agilent Technologies Sales and Service Office. Addresses are provided at the back of this manual.

Typeface Conventions

Bold	Boldface type is used when a term is defined. For example: icons are symbols.
<i>Italic</i>	Italic type is used for emphasis and for titles of manuals and other publications.
[Hardkey]	Indicates a hardkey labeled "Hardkey."
Softkey	Indicates a softkey labeled "Softkey."
[Hardkey] - Softkey1 - Softkey2	Indicates keystrokes [Hardkey] - Softkey1 - Softkey2 .

1. Operation

- Introduction..... 10
- Product Description..... 10
- Specifications 11
- Compensation for Fixture Residual Impedance Error 12
- Operation 13
- DC BIAS..... 14

2. Service

- Maintenance 16

1 **Operation**

Introduction

This chapter provides complete information of the 16065A Test Fixture.

Product Description

The 16065A is a four-terminal-pair type test fixture designed for use with 4 terminal-pair LCR Meters and Impedance Analyzers.

It is intended specifically for applications in which the DUT must be biased by a dc voltage but where the measuring instrument is either not equipped with an internal dc bias source or not capable of outputting the required voltage. Components can be biased at up to ± 200 by connecting an external voltage source to the DC BIAS INPUT BNC connector. Also the dc voltage across the DUT can be monitored at the DC BIAS MONITOR BNC connector. Refer to the DC BIAS for further information.

Three kinds of interchangeable contact inserts see Figure 1-1 are furnished with the 16065A to allow measurement of axial-lead 1 radial-lead 2 or radial, short-lead 3 components.

Figure 1-1

16065A Test Fixture

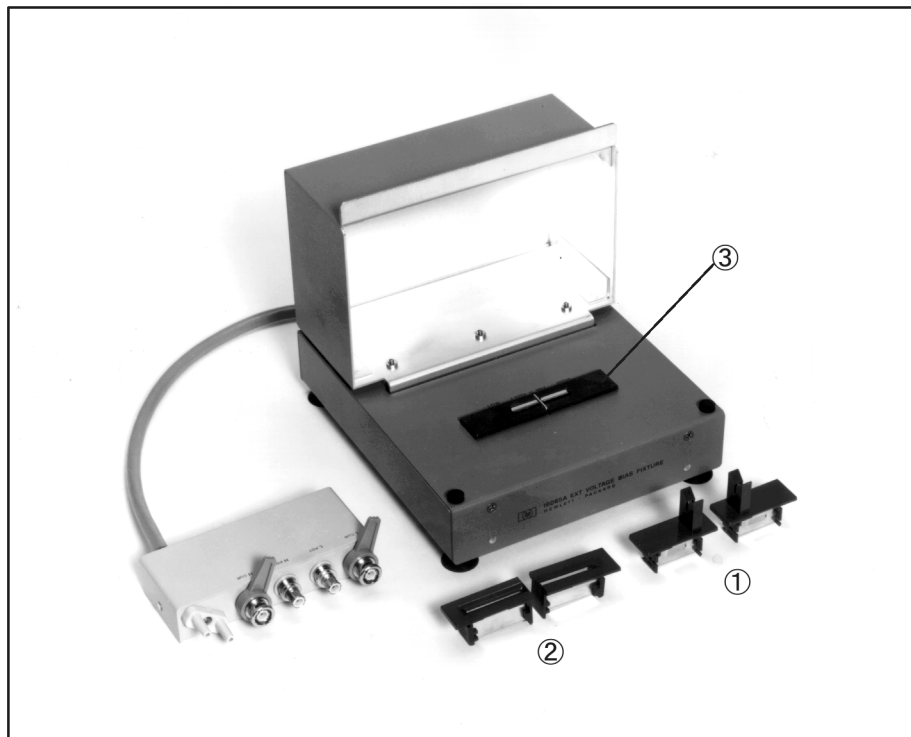

Specifications

Table 1-1 **Specifications of the 16065A**

Function:	Four-terminal-pair type test fixture in applications requiring dc biasing from an external dc voltage source. Contact inserts for axial-lead, radial-lead, and radial, short-lead components are furnished.
External DC Bias:	Up to ± 200 V can be applied to the DC BIAS INPUT BNC
Input Resistance:	$100 \text{ k}\Omega \pm 2 \%$
Frequency Range:	50 Hz to 2 MHz
Series Capacitor:	$5.6 \text{ }\mu\text{F}$ ($560 \text{ }\Omega$ at 50 Hz)
Cable Length:	Approximately 40 cm
Dimensions:	$180 \text{ (W)} \times 120 \text{ (H)} \times 200 \text{ (D)} \text{ mm}$
Weight:	1500 g

Compensation for Fixture Residual Impedance Error

The 16065A has inherent stray capacitance, residual inductance, and residual resistance that affect the accuracy of measured values. To compensate for, or negate, these residuals to minimize measurement error, the instrument's Open/Short compensation procedure should be performed. The procedure is given in the instrument's operating manual. When performing SHORT compensation, use a low impedance copper or phosphor bronze shorting bar. Figure 1-2 shows the recommended shape and dimensions.

Figure 1-2

Shorting-bar Dimensions.

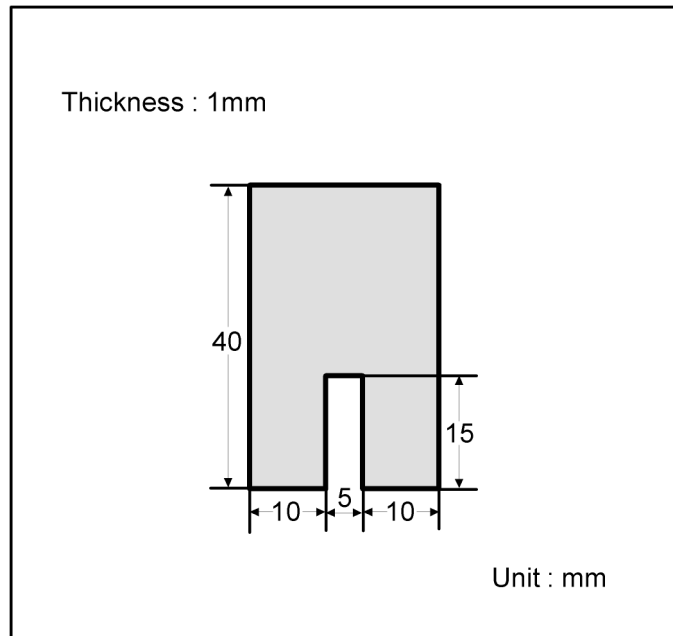

Operation

Step-by-step instructions on how to make a measurement with the 16065A are given below.

1. Set the measuring instrument's CABLE LENGTH switch to the 1m position.
2. Connect the 16065A directly to the measuring instrument's UNKNOWN terminals.
3. Connect the dc voltage source to the 16065A's DC BIAS INPUT BNC connector, and, if necessary, connect a voltage monitor to the DC BIAS MONITOR BNC connector. Do not turn on the voltage source.
4. Perform OPEN and SHORT compensation as described in the measuring instrument's manual.
5. Insert the DUT into the test fixture and close the test fixture lid.

CAUTION Do not short the high and low terminals.

CAUTION When a positive bias voltage is used, the positive terminal of electrolytic capacitors must be connected to the instrument's high terminal. When using a negative bias voltage, connect the capacitor's negative terminal to the instrument's high terminal.

6. Turn on the dc voltage source and adjust it to the desired output voltage.

NOTE When measuring large value capacitors, allow sufficient time for the capacitor to charge to the applied voltage.

NOTE When the 16065A's lid is opened, dc bias voltage from the external voltage source and any charge present on the DUT are shunted to ground through two paralleled 20 Ω resistors.

NOTE The test signal will appear at the DC BIAS MONITOR connector. This does not affect measurement results, however.

DC BIAS

The 16065A contains a 5.6 μF capacitor series connected between the H terminal and the DUT. Its function is to block the applied dc from flowing back into the measuring instrument. Also, because of its location this capacitor makes it impossible to bias samples from the measuring instrument's internal bias source. Thus the 16065A can not be used for applications in which the instrument's internal bias source is used. For these applications use the 16047B Test Fixture.

The external dc voltage source used for biasing samples connected to the 16065A must be capable of outputting 2mA at 200V. Also the 16065A's DC BIAS INPUT has a 100 $\text{k}\Omega$ current limiting resistance which is in series with the DUT. The time required for a capacitive component to charge through this resistance is calculated as

$$T(\text{s}) = 3.5 + (0.5 \times C)$$

Where C is the capacitance of the sample in microfarads (μF).

2 **Service**

Maintenance

An exploded view of the 16065A for parts identification is shown in Figure 2-1 and Figure 2-2. The schematic diagram of the 16065A is given in Figure 2-3. Component locations are shown in Figure 2-4. Table lists the replaceable parts. Do not disassemble any further than shown. Maintenance consists principally of cleaning contacts and replacing worn or damaged parts. Take special care when cleaning contacts. To order parts use the Agilent Technologies partnumbers listed in the table. If a faulty part is located in an assembly that cannot disassembled order the next higher assembly or return the whole device to the nearest Agilent Technologies Sales/Service office for repair or replacement.

Figure 2-1

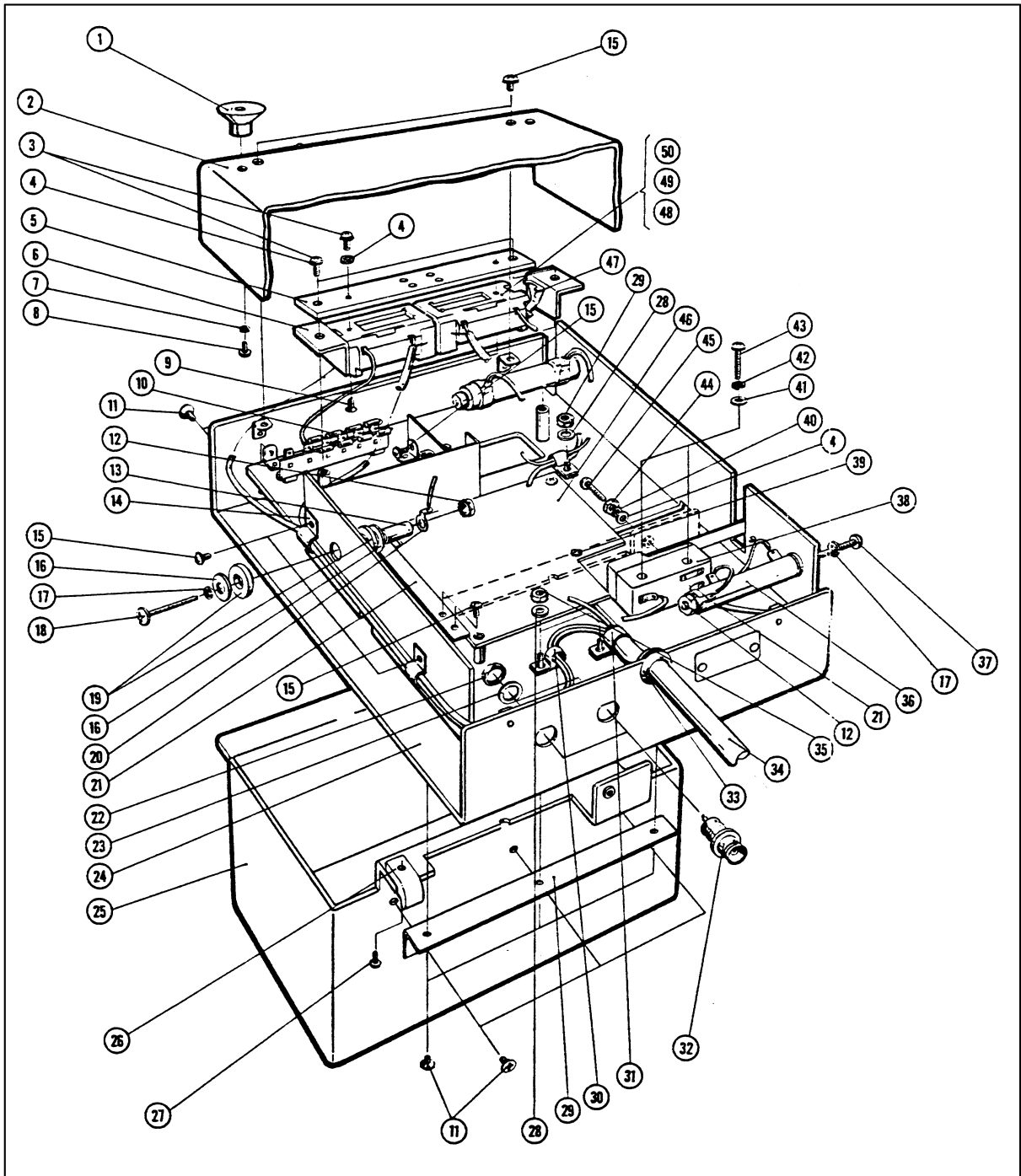

Service
Maintenance

Table 2-1

Reference Designator	Agilent Part Number	Qty.	Description
1	16015-8522	4	FOOT RUBBER
2	16047-04005	1	COVER BOTTOM
3	2200-0109	2	SCREW MACH 4-40
4	2190-0206	4	WSHR-FLAT MET
5	16047-25000	1	PLATE
6	16047-01201	2	ANGLE
7	2190-0226	4	WSHR-LK HLCL MET
8	0515-0924	4	SCREW MACH M3-0.5
9	2200-0165	2	SCREW MACH 4-40
10	1901-1065	8	DIODE POWER CR9-CR16
11	2360-0192	10	SCREW MACH 6-32
12	2580-0006	3	NOT-HEX-W/LKWR
13	0380-0009	1	SPACER-RND.562LG
14	1400-0015	2	CLAMP CABLE
15	2360-0113	9	SCREW MACH 6-32
16	3050-0139	4	WSHR-FL MTLC
17	2190-0017	3	WSHR-LK HLCL
18	2510-0059	1	SCREW MACH 8-32
19	0340-0100	2	INSULATOR-BDG POST
20	0360-0007	2	TERM SOLDER LUG
21	16047-00606	1	CONTACT
22	2950-0001	2	NUT-HEX-DBL-CHAM
23	2190-0016	2	WSHR-LK INTL T
24	16065-04011	1	COVER TOP
25	16065-60011	1	COVER
26	16047-40003	1	CAM
27	0624-0097	1	SCREW TPG 4-40
28	3050-0066	3	WSHR-FL MTLC
29	16047-09000	1	HINGE

Table 2-1

Reference Designator	Agilent Part Number	Qty.	Description
30	1400-0053	2	CLAMP CABLE
31	1400-0017	1	CLAMP CABLE
32	1250-0118	2	CONNECTOR RF BNC
33	0400-0011	2	GROM RND
34	*	1	CABLE-UNSHIELDED
35	2420-0006	3	NUT-HEX-W/LKWR
36	0811-1156	2	RESISTOR 20Ω 5% 20W
37	2510-0136	2	SCREW MACH 8-32
38	3101-0301	1	SWITCH SENSITI-E
39	2200-0103	4	SCREW-MACH 4-40
40	2190-0108	1	WSHR-LK HLCL
41	3050-0010	4	WSHR-FL MTLC
42	2190-0918	2	WSHR-LK HLCL
43	2360-0209	2	SCREW MACH 6-32
44	2260-0001	1	NUT-HEX-DBL-CHAM
45	2200-0147	1	SCREW MACH 4-0
46	16065-66501	1	PC BOARD ASSY DC-CUT
47	16061-10027	2	SPRING-LEAF
48	1460-0343	4	SPRING CPRSN-CYL
49	16061-10026	4	CONTACT
50	16047-40004	2	SOCKET
51	*	2	BNC-ASSY
52	*	4	INSULATOR
53	*	2	CONNECTOR BNC
54	*	1	CO-ER-BOTTOM
55	1400-0719	2	CABLE TIE
56	*	4	SLEEVE-METAL
57	*	4	NUT
58	*	4	NUT-HEX-DBL-CHAM

Service
Maintenance

Table 2-1

Reference Designator	Agilent Part Number	Qty.	Description
59	*	4	WSHR-FL MTLC
60	*	4	WSHR-FL NM
61	16047-40000	1	STOPPER
62	16065-04012	1	COVER TOP
63	2200-0103	1	SCREW MACH 4-40
64	16061-10031	4	CONTACT RADIAL
65	16061-50031	2	SOCKET RADIAL
66	16061-10032	2	CONTACT AXIAL
67	16061-10033	2	CONTACT AXIAL
68	16061-50032	2	SOCKET AXIAL
69	16047-00605	2	CONTACT AXIAL
70	16047-00604	2	CONTACT AXIAL
71	16047-40001	2	SOCKET AXIAL
	16065-60200	1	CABLE ASSY with UNKNOWN BOX
	16065-60100	1	TEST FIXTURE excluding LID and COVER BOTTOM
	16065-60001	1	TEST FIXTURE (1 thru 63)

*: NOT SEPARATELY REPLACEABLE. ORDER 16065-60200

Figure 2-2

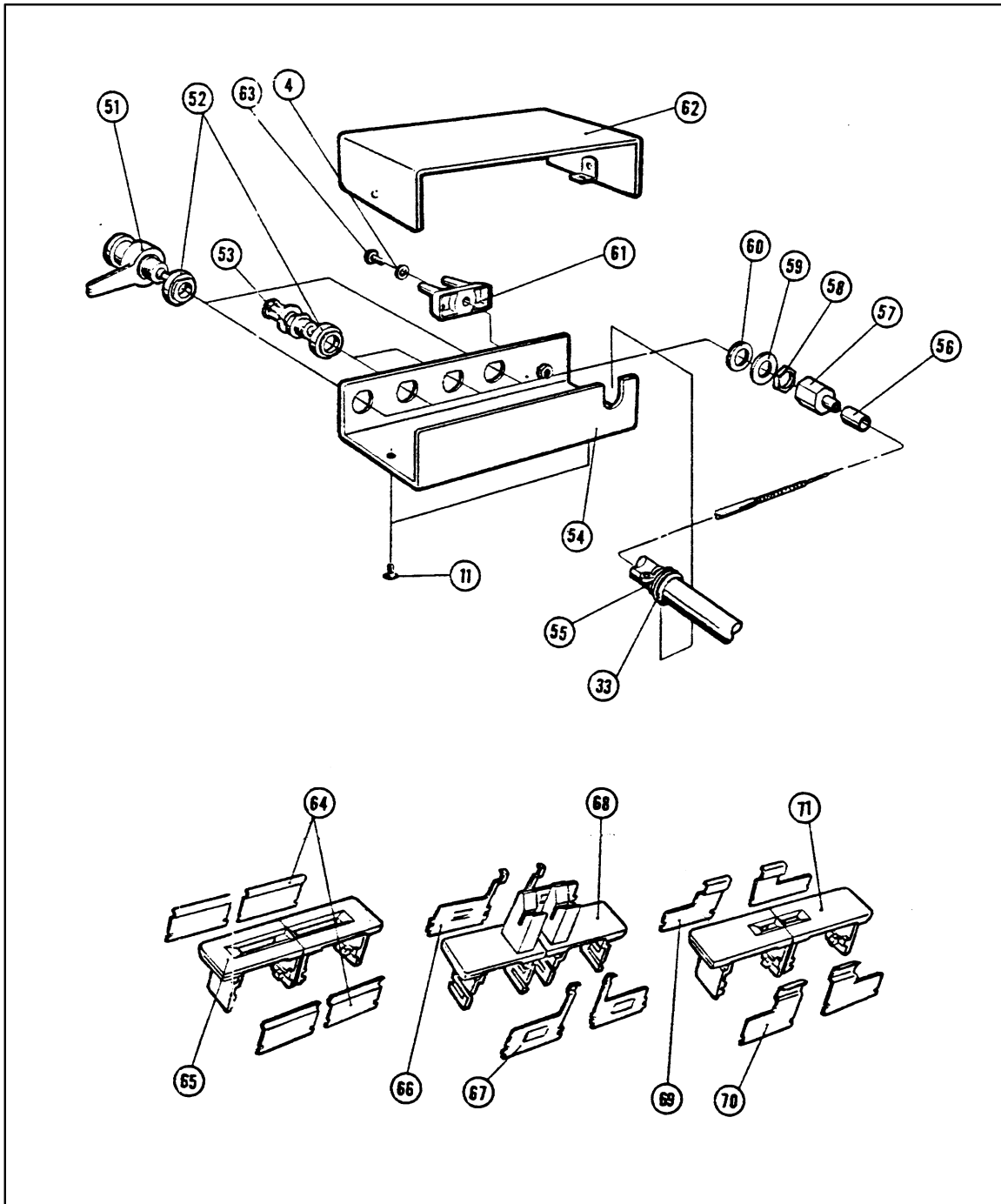

Table 2-2

Reference Designator	Agilent Part Number	Qty.	Description
51	*	2	BNC-ASSY
52	*	4	INSULATOR

Service
Maintenance

Table 2-2

Reference Designator	Agilent Part Number	Qty.	Description
53	*	2	CONNECTOR BNC
54	*	1	COVER-BOTTOM
55	1400-0719	2	CABLE TIE
56	*	4	SLEEVE-METAL
57	*	4	NUT
58	*	4	NUT-HEX-DBL-CHAM
59	*	4	WSHR-FL MTLC
60	*	4	WSHR-FL NM
61	16047-40000	1	STOPPER
62	16065-04012	1	COVER TOP
63	2200-0103	1	SCREW MACH 4-40
64	16061-10031	4	CONTACT RADIAL
65	16061-50031	2	SOCKET RADIAL
66	16061-10032	2	CONTACT AXIAL
67	16061-10033	2	CONTACT AXIAL
68	16061-50032	2	SOCKET AXIAL
69	16047-00605	2	CONTACT AXIAL
70	16047-00604	2	CONTACT AXIAL
71	16047-40001	2	SOCKET AXIAL
	16065-60200	1	CABLE ASSY with UNKNOWN BOX
	16065-60100	1	TEST FIXTURE excluding LID and COVER BOTTOM
	16065-60001	1	TEST FIXTURE (1 thru 63)

Figure 2-3 16065A Schematic Diagram

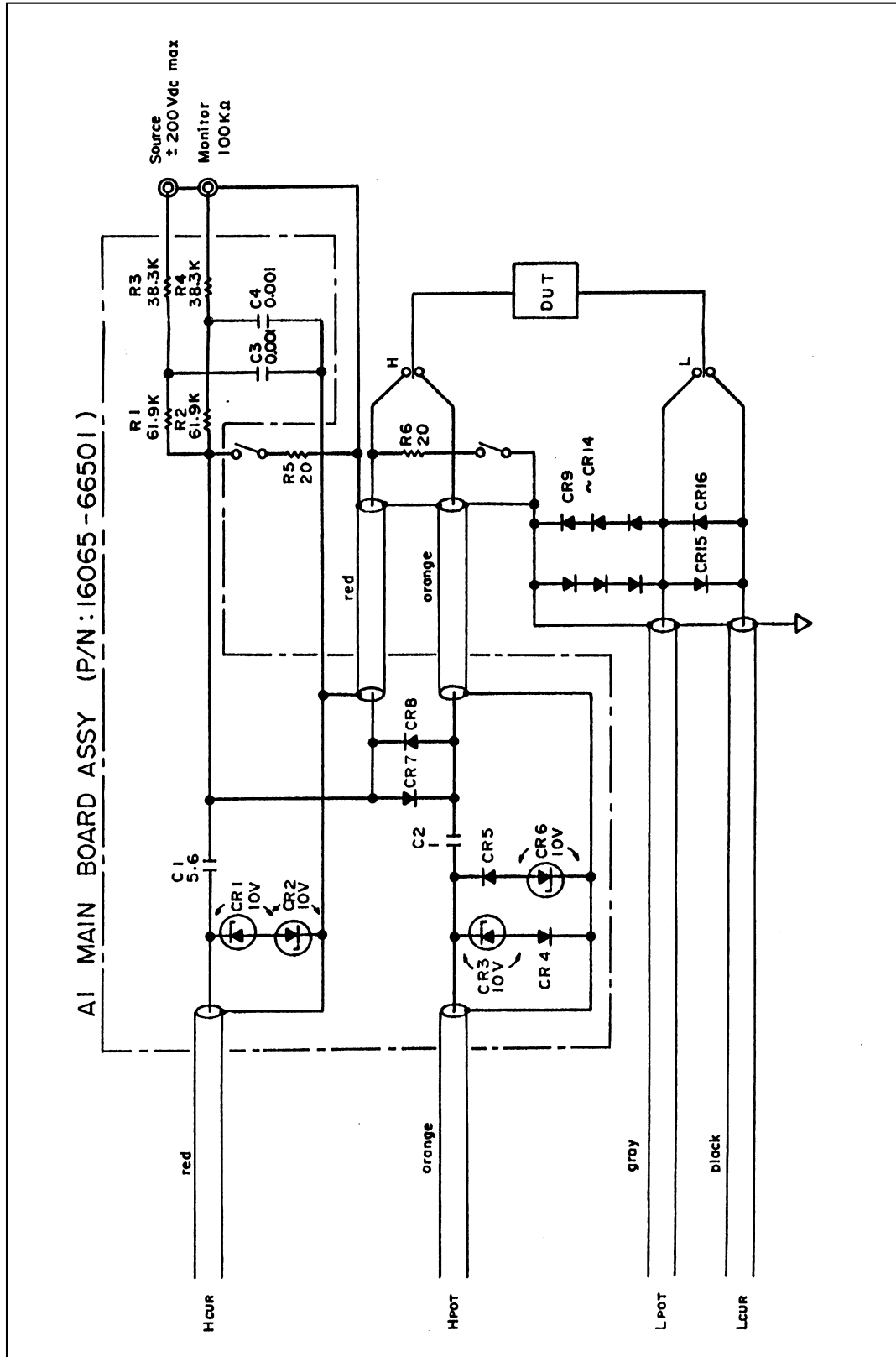

Figure 2-4

A1 Main Board Assembly Component Location

